

SECTION : 9L

GLASS AND MIRRORS

CAUTION : *Disconnect the negative battery cable before removing or installing any electrical unit or when a tool or equipment could easily come in contact with exposed electrical terminals. Disconnecting this cable will help prevent personal injury and damage to the vehicle. The ignition must also be in LOCK unless otherwise noted.*

TABLE OF CONTENTS

<p>SPECIFICATIONS 9L-2</p> <p style="padding-left: 20px;">FASTENER TIGHTENING SPECIFICATIONS 9L-2</p> <p>SPECIAL TOOLS 9L-2</p> <p style="padding-left: 20px;">SPECIAL TOOLS TABLE 9L-2</p> <p>SCHEMATIC AND ROUTING DIAGRAMS 9L-3</p> <p style="padding-left: 20px;">REAR WINDOW DEFOGGER/DAER CIRCUIT 9L-3</p> <p style="padding-left: 20px;">ELECTRIC CONTROL OUTSIDE REARVIEW MIRRORS CIRCUIT 9L-4</p> <p>DIAGNOSIS 9L-5</p> <p style="padding-left: 20px;">TESTING REAR WINDOW DEFOGGER GRID LINE . 9L-5</p> <p style="padding-left: 20px;">OUTSIDE REARVIEW MIRROR DEFOGGERS 9L-5</p> <p style="padding-left: 20px;">ELECTRIC CONTROL OUTSIDE REARVIEW MIRRORS 9L-6</p> <p>MAINTENANCE AND REPAIR 9L-8</p>	<p>ON-VEHICLE SERVICE 9L-8</p> <p>WINDSHIELD 9L-8</p> <p>REAR WINDOW GLASS 9L-10</p> <p>REAR WINDOW DEFOGGER GRID LINE REPAIR 9L-12</p> <p>REAR WINDOW DEFOGGER BRAIDED LEAD WIRE REPAIR 9L-14</p> <p>QUARTER WINDOW (WAGON) 9L-14</p> <p>FRONT DOOR GLASS 9L-15</p> <p>REAR DOOR GLASS 9L-16</p> <p>INSIDE REARVIEW MIRROR 9L-17</p> <p>ELECTRIC CONTROL HEATED OUTSIDE REARVIEW MIRRORS 9L-18</p> <p>GENERAL DESCRIPTION AND SYSTEM</p> <p style="padding-left: 20px;">OPERATION 9L-19</p> <p style="padding-left: 20px;">STATIONARY GLASS 9L-19</p> <p style="padding-left: 20px;">ELECTRIC CONTROL HEATED OUTSIDE REARVIEW MIRRORS 9L-19</p> <p style="padding-left: 20px;">INSIDE REARVIEW MIRROR 9L-19</p>
---	--

SPECIFICATIONS

FASTENER TIGHTENING SPECIFICATIONS

Application	N•m	Lb-Ft	Lb-In
Glass Screws	4.5	–	40
Outside Rearview Mirror Assembly Screws	8	–	71
Rearview Mirror Mounting Screw	1.5	–	13

SPECIAL TOOLS

SPECIAL TOOLS TABLE

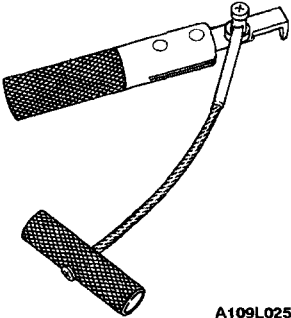
 <p style="font-size: small; margin-top: 5px;">A109L025</p>	<p>J-24402 Glass Sealant Remover</p>
---	--

SCHEMATIC AND ROUTING DIAGRAMS

REAR WINDOW DEFOGGER/DAER CIRCUIT

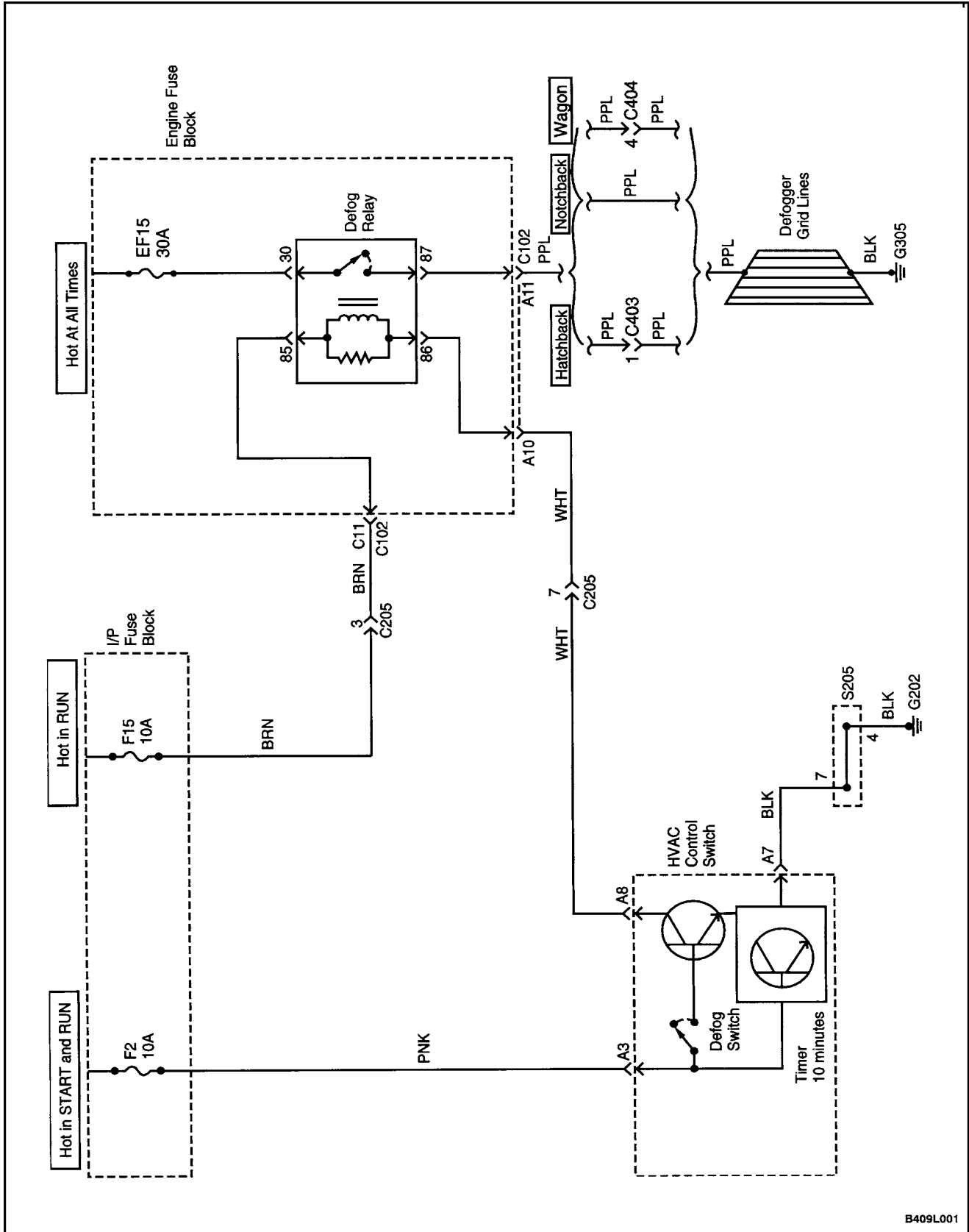

ELECTRIC CONTROL OUTSIDE REARVIEW MIRRORS CIRCUIT

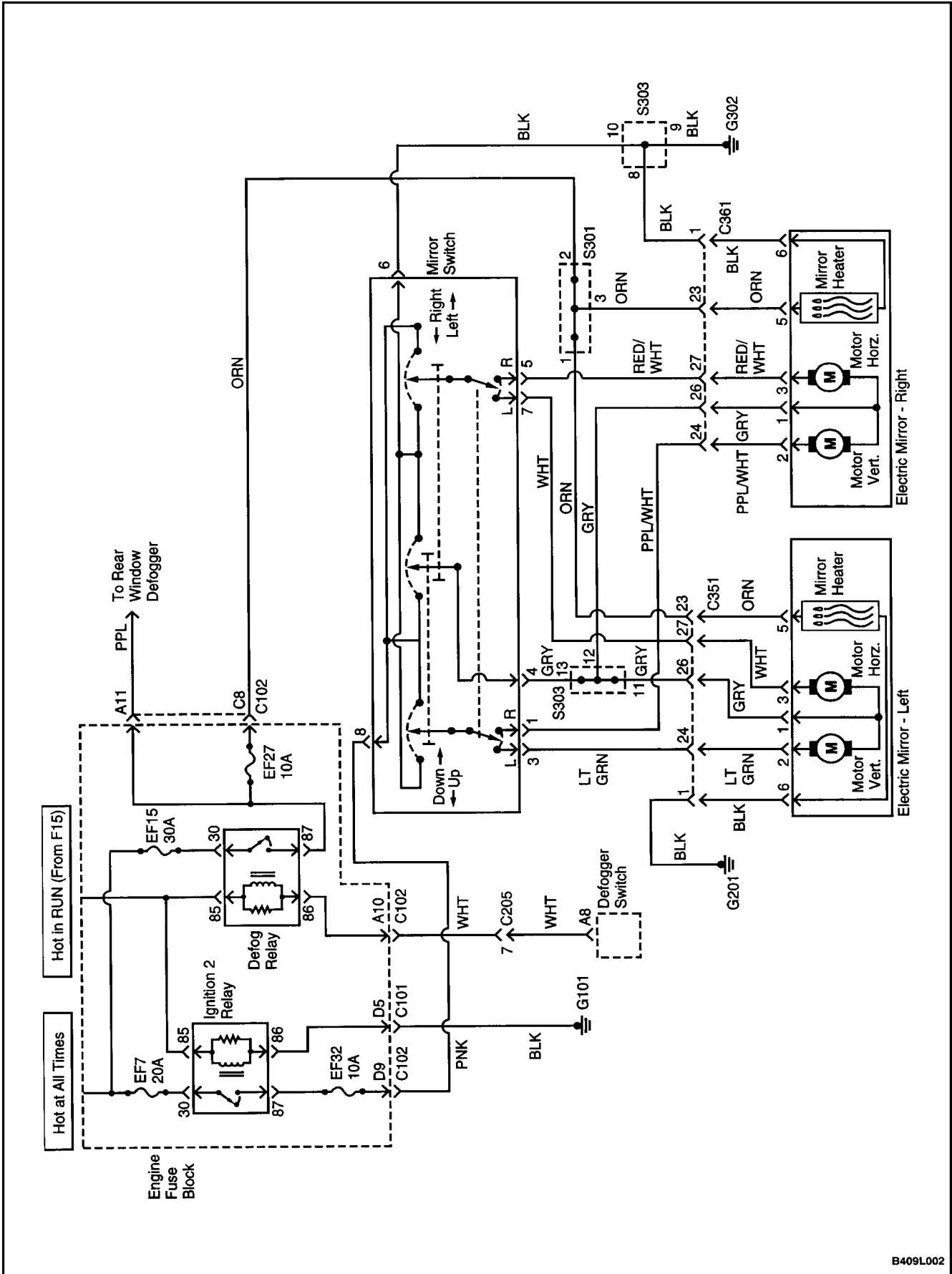

DIAGNOSIS

TESTING REAR WINDOW DEFOGGER GRID LINE

If it has been observed during use that a grid line is inoperative, the following procedure can be used to find the break. If none of the grid lines is operating, a full system diagnosis should be completed before attempting to repair the grid lines.

1. Start the engine.
2. While the engine is running, turn on the rear window defogger.
3. From the inside of the vehicle, connect a voltmeter to each end of a grid line. The voltmeter will indicate battery voltage if the grid line is open.

Notice : Use care when touching the voltmeter terminals a grid line. If the terminals are roughly applied, the grid line may be scratched, resulting in an open circuit.

4. If a grid line is found to be open, move a voltmeter terminal from one side of the grid line and re-test at a point nearer to the other side of the window. Continue to re-test, each time bringing one of the voltmeter terminals closer to the opposite side of the window from where it was originally connected. The break in the grid line is at the point where the voltmeter begins reading 0 volts instead of battery voltage.
5. Use a marking crayon to mark lightly the break point on the rear window. Mark the glass instead of marking directly on the grid line, and make the mark far enough from the grid line so that it can easily be removed without disturbing the repair.
6. Use a grid line repair kit to fix the break in the grid line. Refer to "Rear Window Defogger Grid Line Repair" in this section.

OUTSIDE REARVIEW MIRROR DEFOGGERS

Step	Action	Value(s)	Yes	No
1	Check the rear window defogger. Does the rear window defogger work?		Go to <i>Step 4</i>	Go to <i>Step 2</i>
2	Repair the rear window defogger before proceeding with the outside mirror diagnosis. Is the repair complete?		Go to <i>Step 3</i>	
3	Test the outside mirror defoggers. Does the repair of the rear window defogger system also fix the problem with the outside mirror defoggers?		System OK	Go to <i>Step 4</i>
4	Check fuse EF27. Is fuse EF27 blown?		Go to <i>Step 5</i>	Go to <i>Step 6</i>
5	1. Check for a short circuit and repair it, if necessary. 2. Replace the fuse. Is the repair complete?		System OK	
6	1. On the side of the vehicle which has the malfunctioning mirror defogger, remove the black plastic escutcheon from the trim panel side of the door. 2. Disconnect the outside mirror electrical connector. 3. Turn the ignition ON. 4. Turn on the defogger. 5. Use a voltmeter to backprobe terminal 5 (ORN) at the mirror electrical connector. Does the voltmeter indicate the specified value?	11–14 v	Go to <i>Step 8</i>	Go to <i>Step 7</i>
7	Repair the open circuit between fuse EF27 and the mirror connector. Is the repair complete?		System OK	

9L – 6 GLASS AND MIRRORS

Step	Action	Value(s)	Yes	No
8	<ol style="list-style-type: none"> 1. Turn the ignition OFF. 2. Disconnect the outside mirror electrical connector. 3. Use an ohmmeter to measure the resistance between terminal 6 (BLK) of the mirror connector and ground. Does the ohmmeter indicate the specified value?	$\approx 0 \Omega$	Go to <i>Step 10</i>	Go to <i>Step 9</i>
9	Repair the open ground circuit for the outside rearview mirror. Is the repair complete?		System OK	
10	Replace the defective outside rearview mirror. Is the repair complete?		System OK	

ELECTRIC CONTROL OUTSIDE REARVIEW MIRRORS

Outside Rearview Mirrors Do Not Adjust

Step	Action	Value(s)	Yes	No
1	Check fuse EF32. Is fuse EF32 blown?		Go to <i>Step 2</i>	Go to <i>Step 3</i>
2	<ol style="list-style-type: none"> 1. Check for a short circuit and repair it, if necessary. 2. Replace fuse EF32. Is the repair complete?		System OK	
3	Turn the ignition ON. Check the voltage at fuse EF32. Is the voltage at EF32 equal to the specified value?	11–14 v	Go to <i>Step 5</i>	Go to <i>Step 4</i>
4	Repair the open power supply circuit for fuse EF32. Is the repair complete?		System OK	
5	Check the power mirrors. Are both power mirrors inoperative?		Go to <i>Step 6</i>	Go to <i>Step 13</i>
6	<ol style="list-style-type: none"> 1. Remove the retaining screw for the door power mirror and power window switch assembly. 2. Lift the switch assembly so the connectors on the underside are visible. Is the connector secured to the power mirror switch?		Go to <i>Step 8</i>	Go to <i>Step 7</i>
7	Connect the connector to the power mirror switch. Is the repair complete?		System OK	
8	Use an ohmmeter to check the continuity between terminal 6 (BLK) of the mirror switch connector and ground. Does the ohmmeter indicate the specified value?	$\approx 0 \Omega$	Go to <i>Step 10</i>	Go to <i>Step 9</i>
9	Repair the open ground circuit for the mirror switch. Is the repair complete?		System OK	
10	<ol style="list-style-type: none"> 1. Turn the ignition ON. 2. Check the voltage at terminal 8 (PNK) of the mirror switch connector. Is the voltage equal to the specified value?	11–14 v	Go to <i>Step 12</i>	Go to <i>Step 11</i>
11	Repair the open power supply circuit for the mirror switch. Is the repair complete?		System OK	

Step	Action	Value(s)	Yes	No
12	Replace the outside rearview mirror switch. Is the repair complete?		System OK	
13	<ol style="list-style-type: none"> 1. On the side which has the inoperative mirror, remove the black plastic escutcheon from the trim panel side of the door. 2. Disconnect the outside mirror electrical connector. 3. Turn the ignition ON. 4. At the outside mirror connector, connect a voltmeter between terminal 1 (GRY) and terminal 2 (LTGRN, if testing the left side; or PPL/WHT, if testing the right side). 5. Operate the in/out adjustment on the switch, and record the voltage indicated in each switch position. 6. Connect a voltmeter between terminal 1 (GRY) and terminal 3 (WHT, if testing the left side; or RED/WHT, if testing the right side). 7. Operate the up/down adjustment on the switch, and record the voltage indicated in each switch position. <p>Does the voltmeter indicate the specified voltage for each test, with the polarity reversing when the switch is changed from in to out, or up to down?</p>	11–14 v	Go to <i>Step 14</i>	Go to <i>Step 15</i>
14	Replace the outside rearview mirror. Is the repair complete?		System OK	
15	<ol style="list-style-type: none"> 1. Remove the retaining screw for the power door mirror and power window switch assembly. 2. Lift the switch assembly so the connectors on the underside are visible. 3. Leave the outside mirror disconnected, but do not disconnect the mirror switch connector. 4. Turn the ignition ON. 5. At the mirror switch connector, backprobe to measure the voltage between terminal 1 (GRY) and terminal 2 (LTGRN, if testing the left side; or PPL/WHT, if testing the right side). 6. Operate the in/out adjustment on the switch, and record the voltage indicated in each switch position. 7. Connect a voltmeter between terminal 1 (GRY) and terminal 3 (WHT, if testing the left side; or RED/WHT, if testing the right side). 8. Operate the up/down adjustment on the switch, and record the voltage indicated in each switch position. <p>Does the voltmeter indicate the specified voltage for each test, with the polarity reversing when the switch is changed from in to out or up to down?</p>	11–14 v	Go to <i>Step 16</i>	Go to <i>Step 12</i>
16	Repair the open circuit between the mirror switch and the outside rearview mirror connector. Is the repair complete?		System OK	

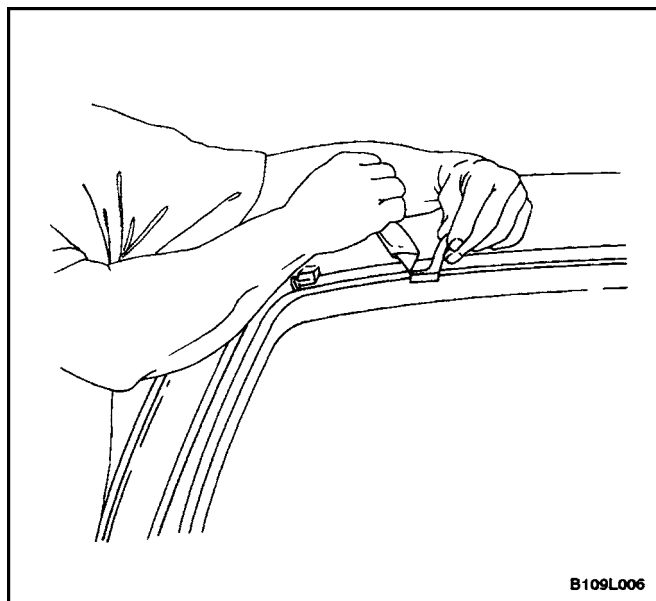
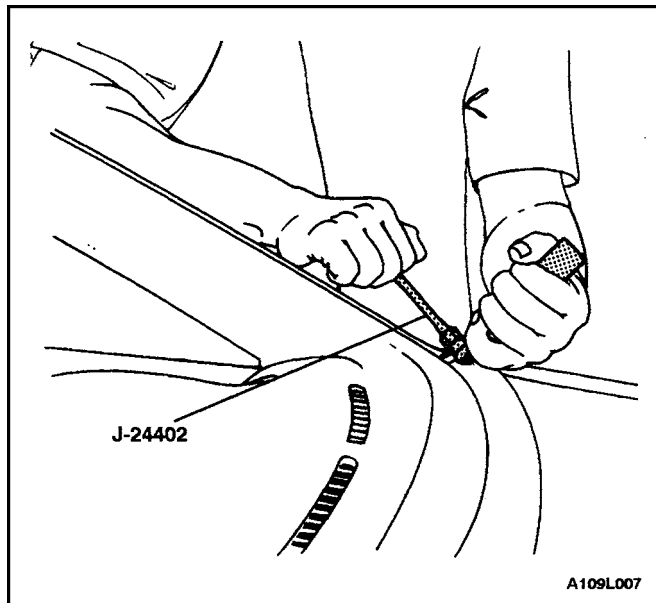
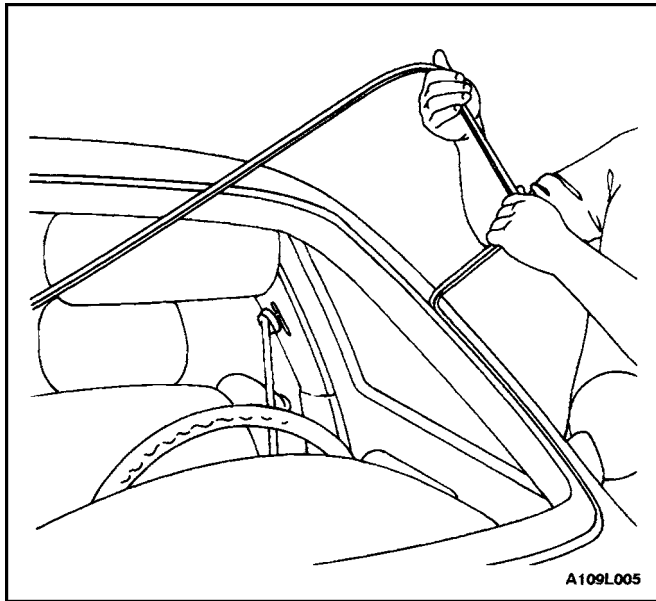

MAINTENANCE AND REPAIR

ON-VEHICLE SERVICE

WINDSHIELD

Tools Required

J-24402 Glass Sealant Remover

Removal Procedure

1. Remove the cowl vent grille. Refer to *Section 9R, Body Front End*.
2. Remove the inside rearview mirror. Refer to "Inside Rearview Mirror" in this section.
3. Remove the weatherstrip around the windshield.
4. Using the glass sealant remover J-24402, cut the adhesive around the windshield.
5. Remove the windshield from the vehicle..
6. Using a knife, remove the adhesive from the windshield.
7. Using a knife, remove the adhesive from the windshield frame.

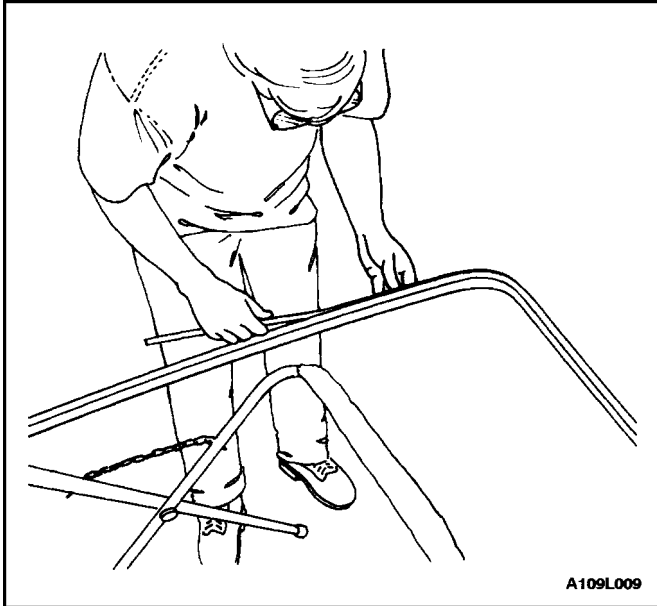

A109L009

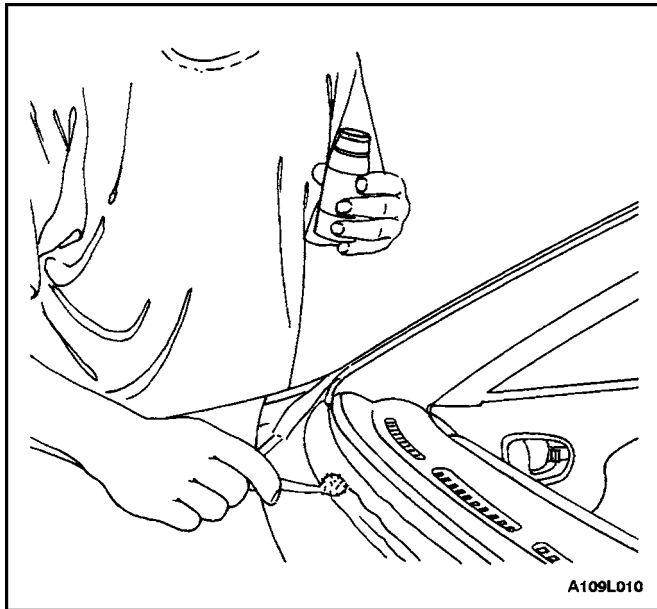

A109L010

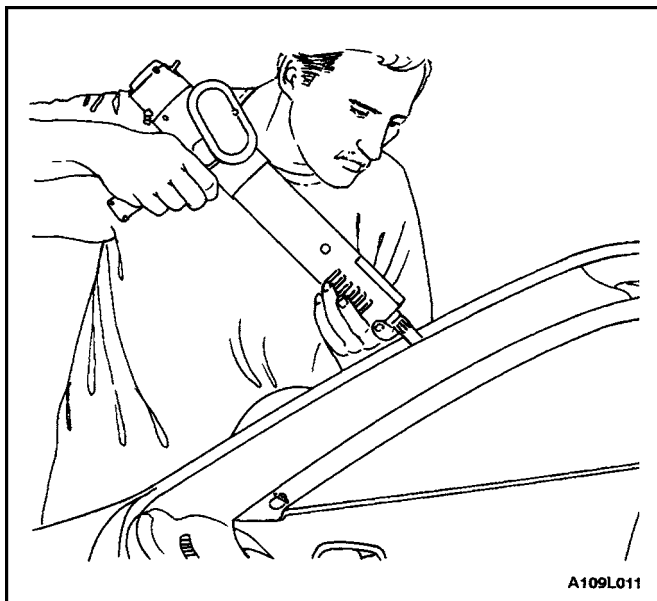

A109L011

Installation Procedure

1. Install the new weatherstrip to the windshield.
2. Apply tape to the new weatherstrip and the windshield to hold the weatherstrip in place.
3. Apply adhesive primer to the windshield frame and the perimeter of the windshield.
4. Apply glass adhesive to the windshield frame.
5. Install the windshield into the windshield frame.
6. Reposition the tape over the weatherstrip, the windshield, and the windshield frame to hold the windshield in place.
7. Let the adhesive dry for 24 hours.
8. Remove the tape.
9. Check for waterleaks by pouring water on the windshield. If a leak is found, dry the windshield and fill the area that leaks with adhesive. If the leak persists, remove the windshield and repeat the entire procedure.
10. Install the inside rearview mirror. Refer to "Inside Rearview Mirror" in this section.
11. Install the cowl vent grille. Refer to *Section 9R, Body Front End*.

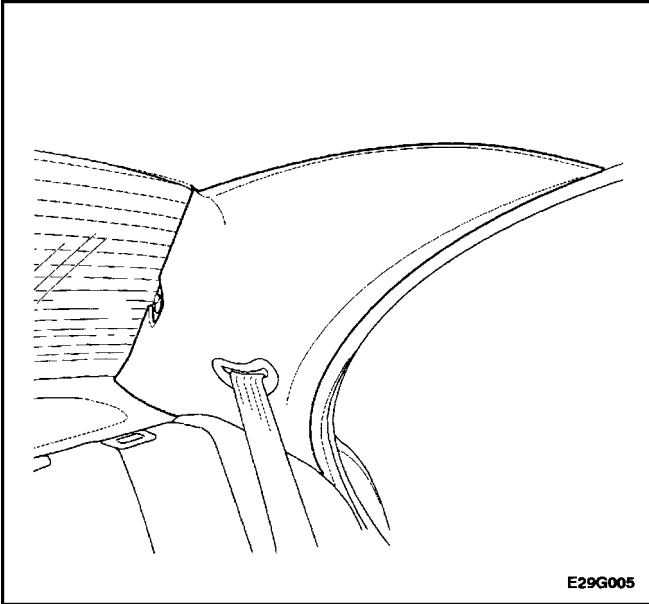

REAR WINDOW GLASS

(Notchback Shown, Hatchback and Wagon Similar)

Tools Required

J-24402 Glass Sealant Remover

Removal Procedure

1. Disconnect the negative battery cable.
2. Remove the rear window wiper (wagon only). Refer to *Section 9D, Wipers/Washer Systems*.
3. Disconnect the rear window defogger electrical connector.

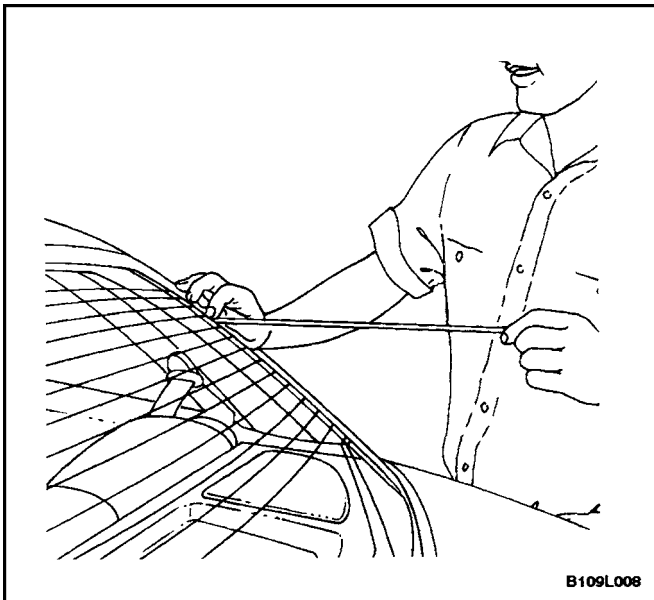

4. Remove the weatherstrip around the rear window.

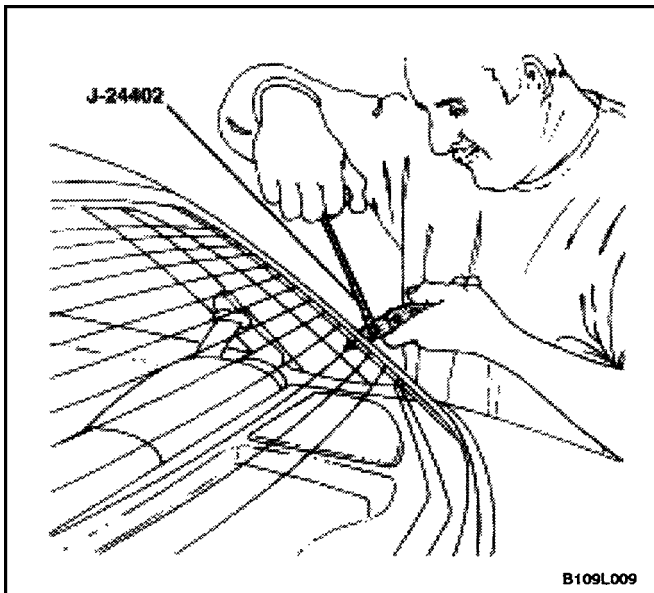

5. Using the glass sealant remover J-24402, cut the adhesive around the rear window.

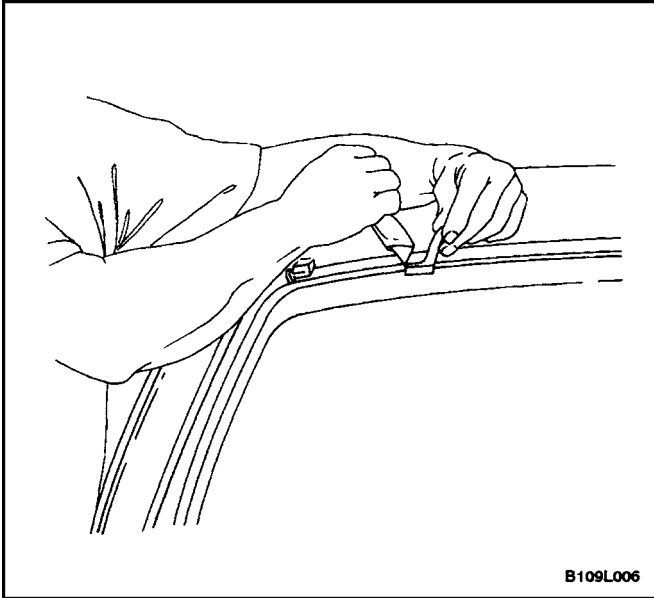

6. Remove the rear window from the vehicle.
7. Using a knife, remove the adhesive from the rear window.
8. Using a knife, remove the adhesive from the rear window frame.

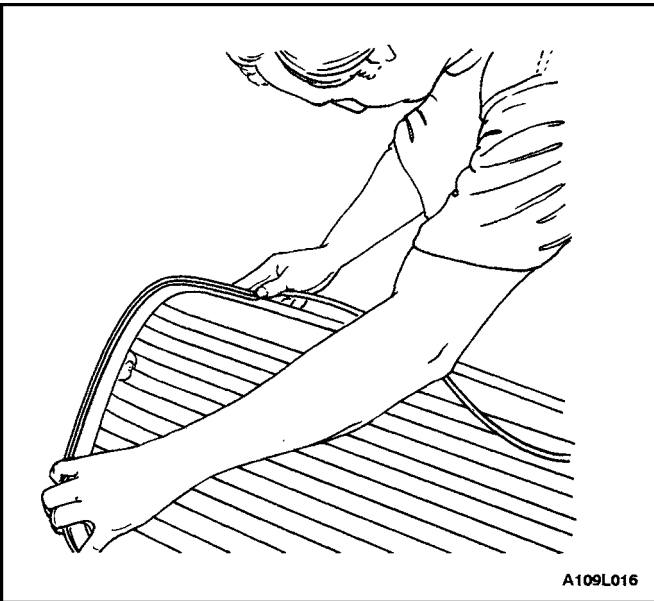

Installation Procedure

1. Install the new weatherstrip to the rear window.

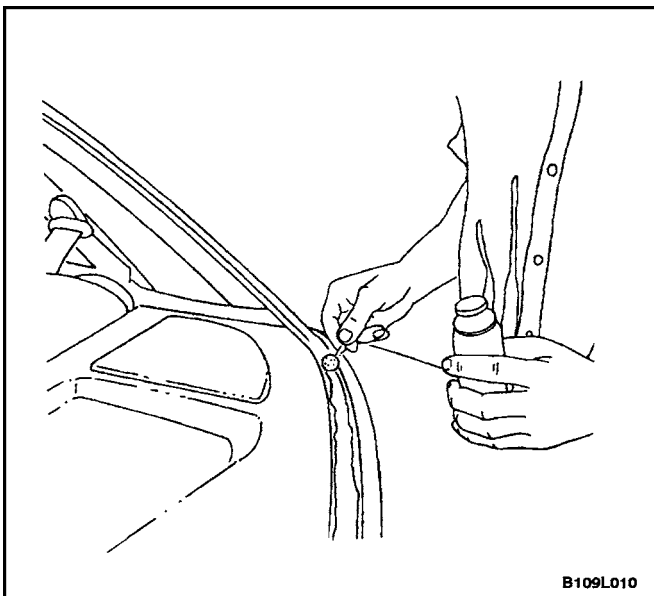

2. Apply tape to the new weatherstrip and the rear window to hold the weatherstrip in place.
3. Apply adhesive primer to the rear window frame and the perimeter of the rear window.

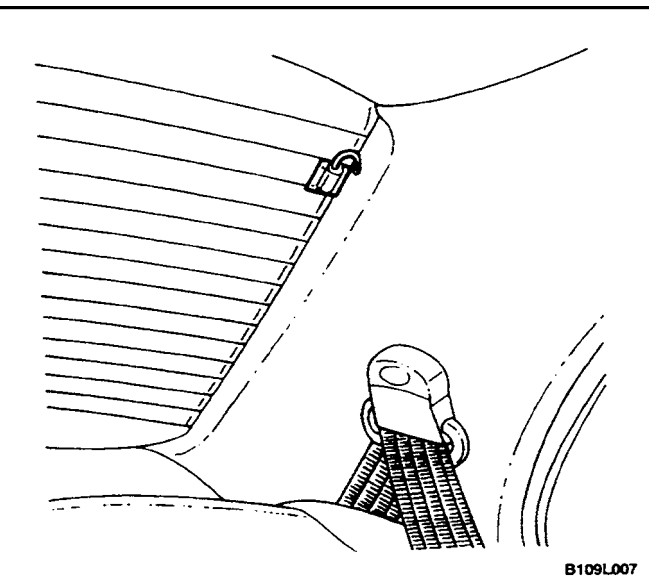
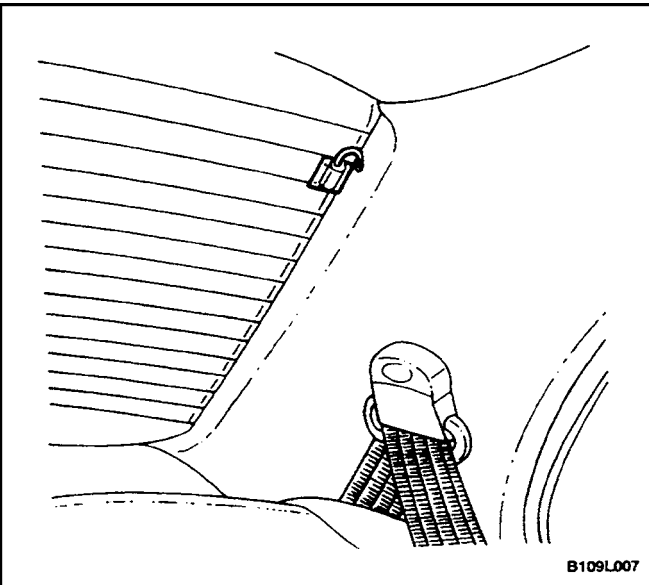
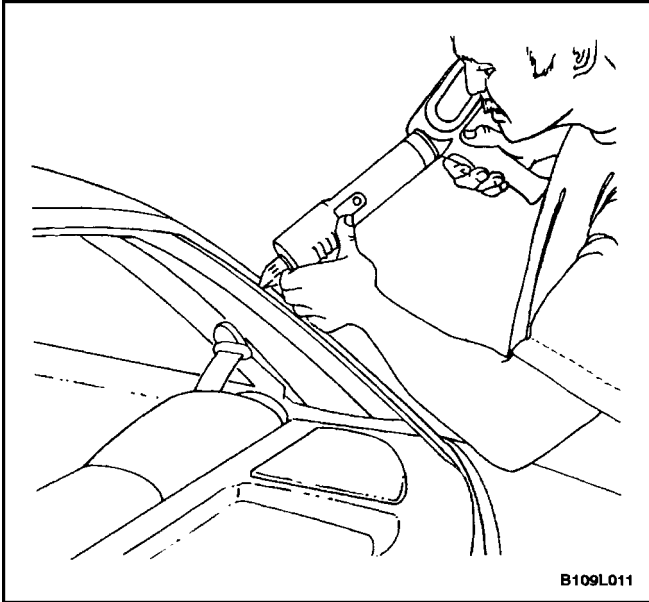

4. Apply glass adhesive to the rear window frame.

5. Install the rear window into the rear window frame.
6. Reposition the tape over the weatherstrip, the rear window, and the rear window frame to hold the rear window in place.
7. Let the adhesive dry for 24 hours.
8. Remove the tape.
9. Check for waterleaks by pouring water on the rear window. If a leak is found, dry the window and fill the area that leaks with adhesive. If the leak persists, remove the rear window and repeat the entire procedure.
10. Connect the rear window defogger electrical connector.
11. Install the rear window wiper (wagon only). Refer to *Section 9D, Wipers/Washer Systems*.
12. Connect the negative battery cable.

REAR WINDOW DEFOGGER GRID LINE REPAIR

(Notchback Shown, Hatchback and Wagon Similar)

1. Disconnect the negative battery cable.
2. Disconnect the rear window defogger electrical connectors.
3. Inspect the rear window defogger grid lines.
4. Mark the grid line break on the outside of the glass with a wax pencil or a crayon.
5. Buff the grid lines that are to be repaired with steel wool. Wipe the lines clean using a cloth dampened with alcohol. Buff and clean about 6 mm (0.25 inch) beyond each side of the break in the grid line.

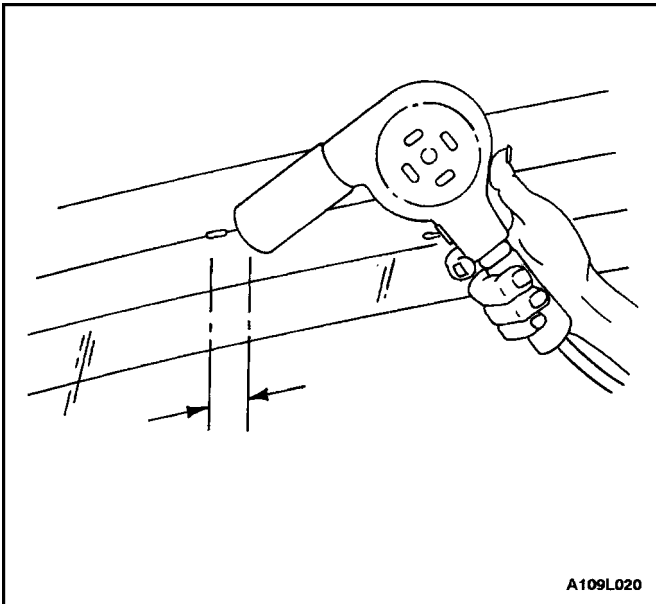
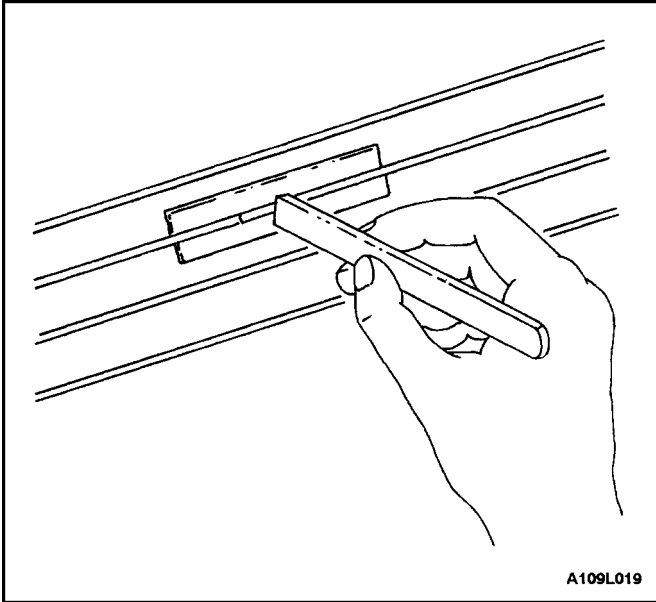

6. Attach a grid line repair decal or two strips of tape above and below the repair areas.
 - A repair decal or tape must be used in order to control the width of the repair areas.
 - If a decal is used, the die-cut metered slot must be the same width as the grid line.
7. Apply the grid repair material to the repair area using a small wooden stick or a spatula. The grid repair material should be at room temperature..
8. Carefully remove the decal or the tape..

Notice : The grid line repair material must be cured with heat. In order to avoid heat damage to the interior trim, protect the trim near the repair area where heat will be applied.

9. Heat the repair area for 1 to 2 minutes.
10. Hold the heat gun nozzle 25 mm (1 inch) from the surface. A minimum temperature of 149°C (300°F) is required.
11. Inspect the grid line repair area. If the repair appears discolored, apply a coating of tincture of iodine to the area using a pipe cleaner or a line brush. Allow the iodine to dry for about 30 seconds. Carefully wipe off the excess iodine with a lint-free cloth.
12. Connect the rear window defogger electrical connectors.
13. Test the operation of the rear window defogger in order to verify that the repair was successful.

Important : At least 24 hours is required for complete curing of the repair materials. The repair area should not be physically disturbed until after that time.

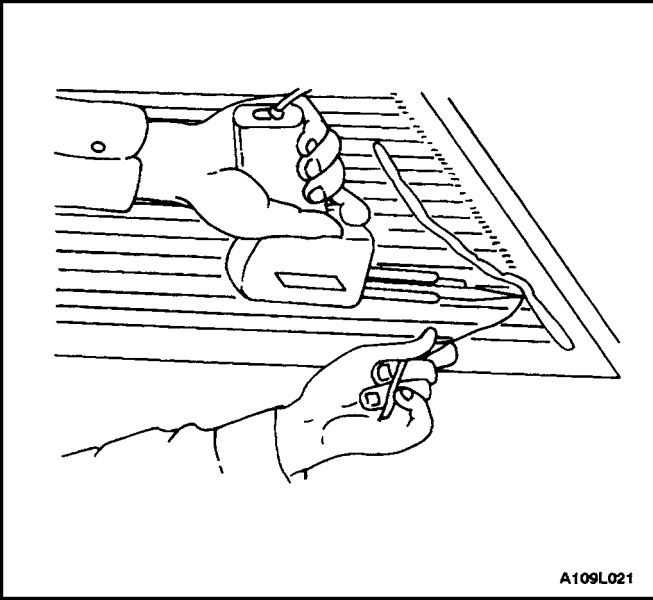

A109L021

REAR WINDOW DEFOGGER BRAIDED LEAD WIRE REPAIR

The rear window defogger bus lead wire or the terminal can be reattached by resoldering. Use a solder containing 3 percent silver and a rosin flux paste.

1. The repair area should be buffed with fine steel wool before soldering the bus lead wire.
2. Apply the paste-type rosin flux in small quantities to the wire lead and the bus lead wire repair area using a brush.
3. Coat the soldering iron tip with solder. Use only enough solder to ensure a complete repair.
4. Use only enough heat to melt the solder. Do not overheat the wire when resoldering to the bus lead wire.

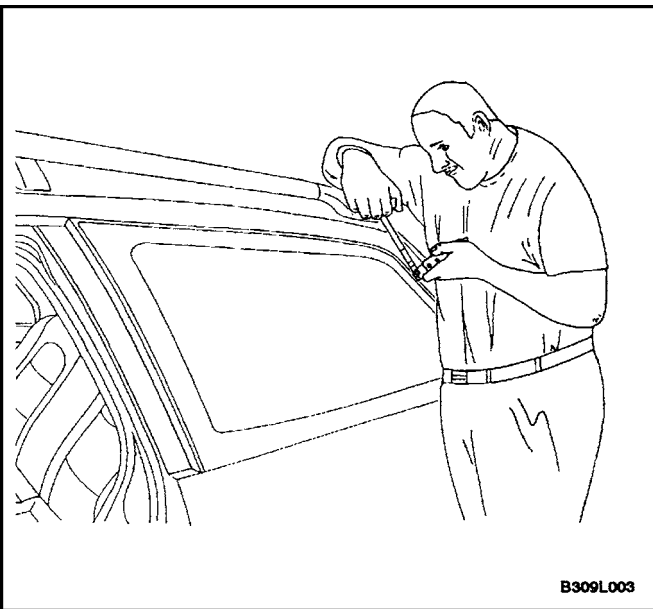

B309L003

QUARTER WINDOW (WAGON)

Tools Required

J-24402 Glass Sealant Remover

Removal Procedure

1. Remove the quarter windowmolding. Refer to Section 9M, Exterior Trim.
2. Using the glass sealant remover J-24402, cut the adhesive around the quarter window.
3. Remove the quarter window from the vehicle.
4. Using a knife, remove the adhesive from the quarter window.
5. Using a knife, remove the adhesive from the quarter window frame.

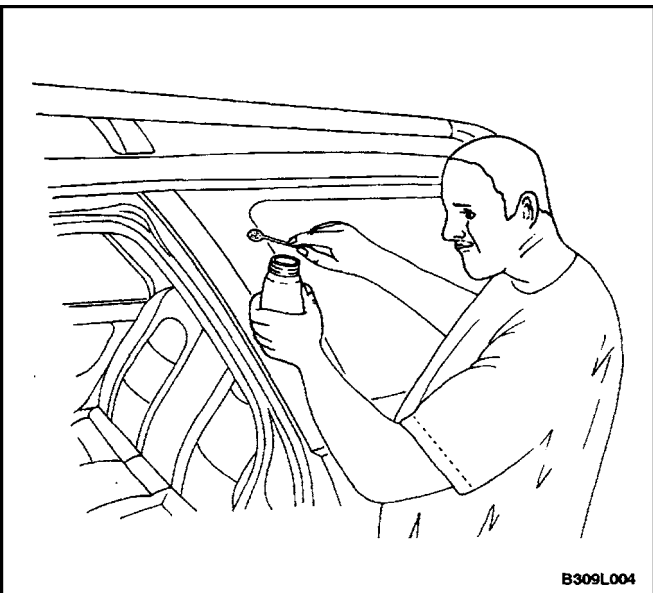

B309L004

Installation Procedure

1. Apply adhesive primer to the quarter window frame and the perimeter of the quarter window.

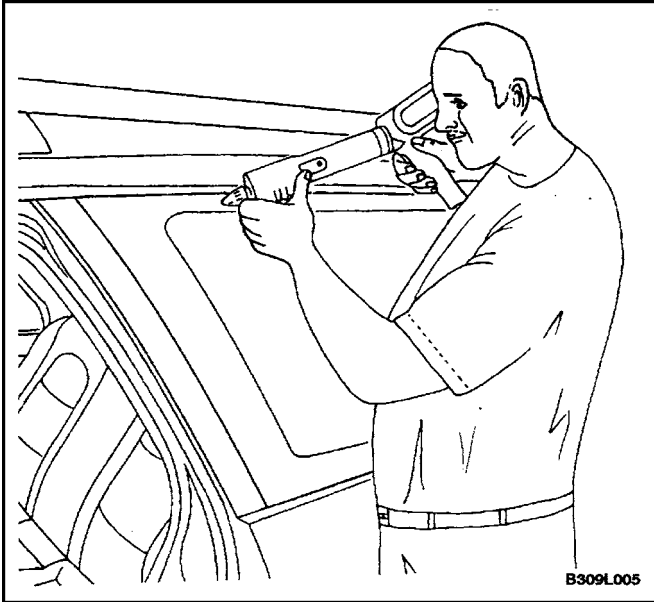

B309L005

2. Apply glass adhesive to the quarter window frame.
3. Install the quarter window into the quarter window frame.
4. Reposition the tape over the quarter window and the quarter window frame to hold the quarter window in place.
5. Let the adhesive dry for 24 hours.
6. Remove the tape.
7. Check for waterleaks by pouring water on the quarter window. If a leak is found, dry the window and fill the area that leaks with adhesive. If the leak persists, remove the quarter window and repeat the entire procedure.

FRONT DOOR GLASS

Removal Procedure

1. Remove the door seal trim. Refer to *Section 9P, Doors*.
2. Remove the screws that secure the glass to the window regulator.
3. Remove the glass from the door.

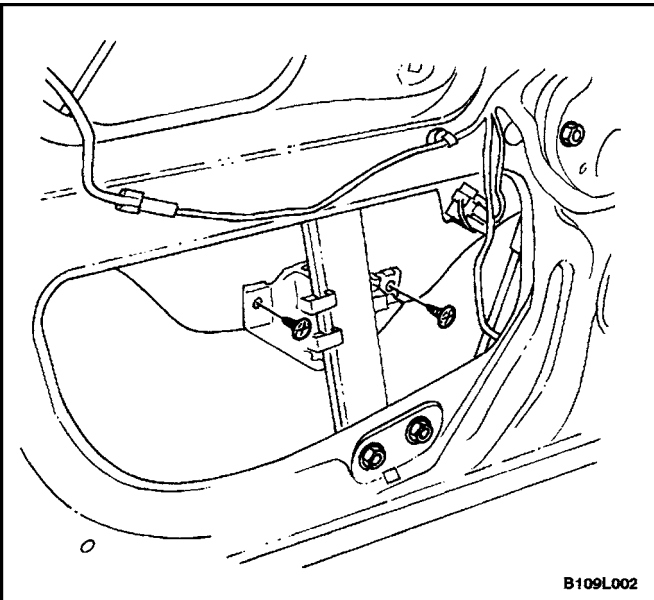

B109L002

Installation Procedure

1. Install the glass in the door and position the glass within the window regulator.

Notice : Dissimilar metals in direct contact with each other may corrode rapidly. Make sure to use the correct fasteners to prevent premature corrosion.

2. Install the glass to the window regulator with the screws.

Tighten

Tighten the glass screws to 4.5 N•m (40 lb-in).

3. Install the door seal trim. Refer to *Section 9P, Doors*.

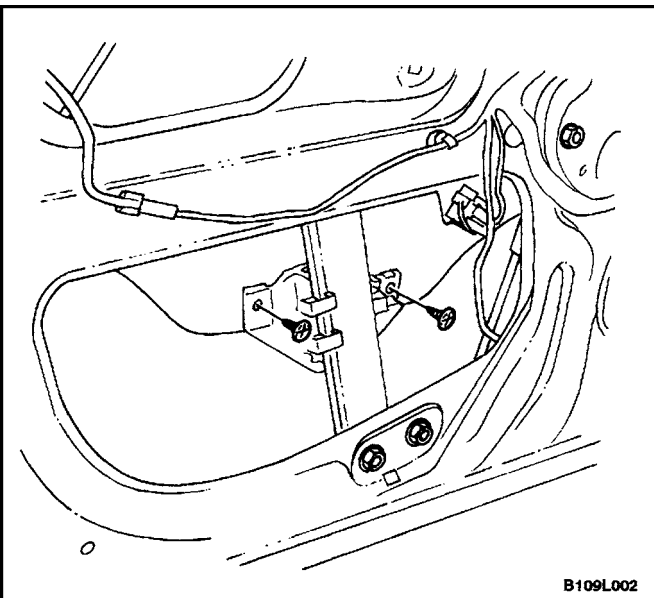

B109L002

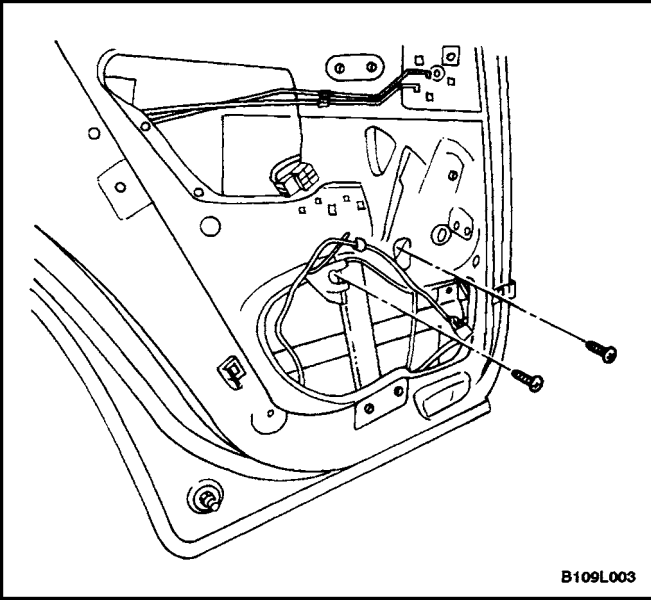

B109L003

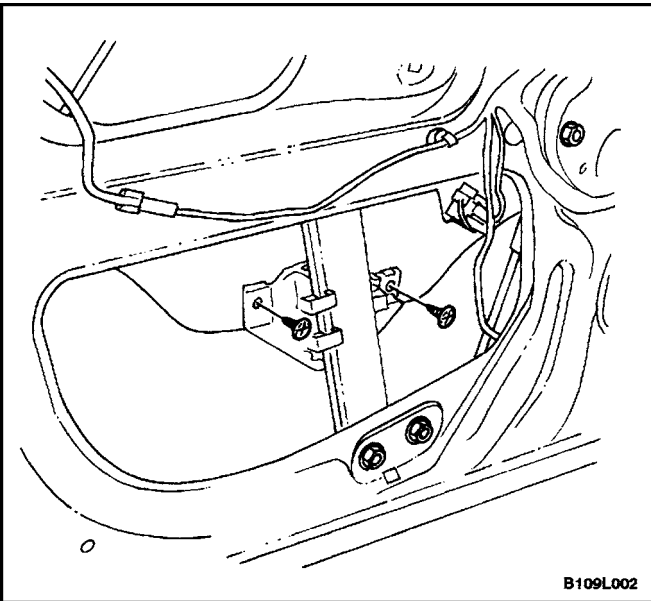

B109L002

REAR DOOR GLASS

Removal Procedure

1. Remove the door seal trim. Refer to *Section 9P, Doors*.
2. Remove the exterior B-pillar molding. Refer to *Section 9M, Exterior Trim*.
3. Remove the screws that secure the glass to the window regulator.
4. Remove the glass from the door.

Installation Procedure

1. Install the glass in the door and position the glass within the window regulator.

Notice : Dissimilar metals in direct contact with each other may corrode rapidly. Make sure to use the correct fasteners to prevent premature corrosion.

2. Install the glass screws.

Tighten

Tighten the glass screws to 4.5 N•m (40 lb-in).

Install the exterior B-pillar molding. Refer to *Section 9M, Exterior Trim*.

Install the door seal trim. Refer to *Section 9P, Doors*.

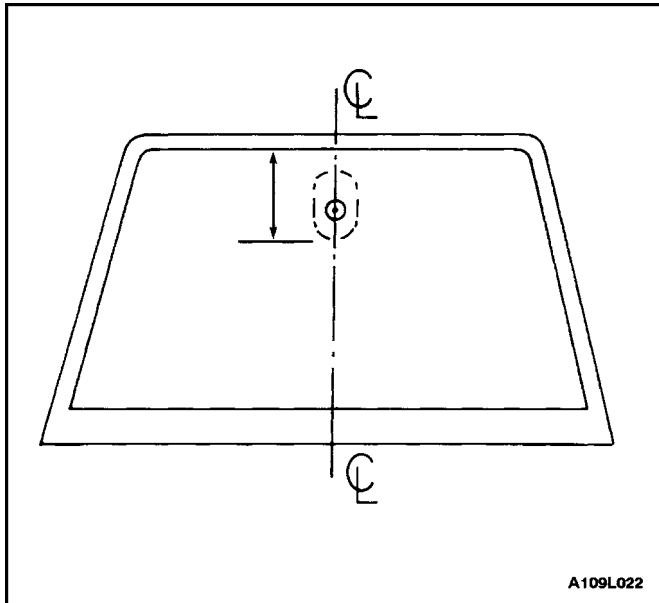

INSIDE REARVIEW MIRROR

The inside rearview mirror is attached to a support which is secured to the windshield glass. The support is installed by the glass supplier using a plastic–polyvinyl butyl adhesive.

Service replacement windshield glass has the mirror support bonded to the glass assembly. In order to install a detached mirror support or to install a new part, the following items will be needed:

- Loctite® Minute–Bond Adhesive.
- Original or replacement mirror support.
- Wax marking pencil or crayon.
- Rubbing alcohol.
- Clean paper towel.
- Fine grit sandpaper (grit #320 or #360).
- 2 mm allen wrench.

Installation Procedure

1. Measure the distance from the headliner to the bottom of the location where the mirror support will be mounted on the windshield.

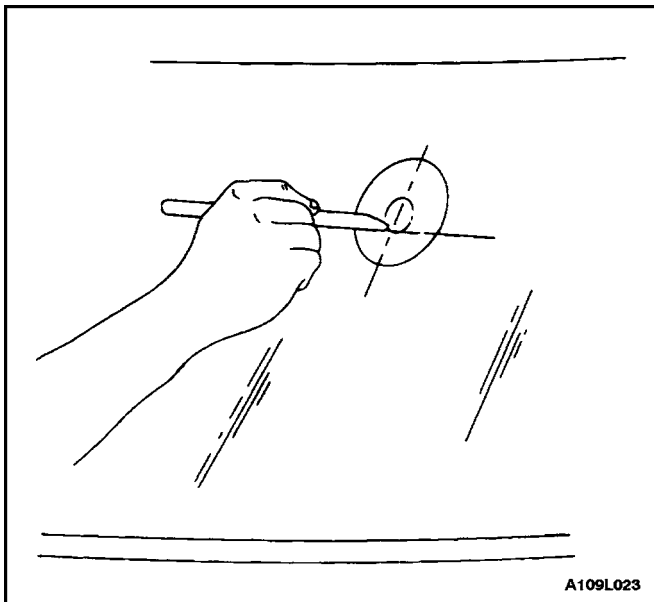

2. Mark this position on the outside of the glass with a wax pencil or crayon. Draw a large diameter circle around the mirror support location on the outside of the glass.
3. Clean the inside surface of the glass with a domestic scouring cleanser, a glass cleaning solution, or a polishing compound and paper towels. Rub the glass until the area is completely dry. When the area is dry, clean the area with an alcohol–saturated paper towel in order to remove any traces of the scouring powder or the glass cleaning solution.
4. If the mirror support is new, clean the bonding surface with fine grit sandpaper #320 or #360. If the original mirror support is being used, all traces of factoryinstalled adhesive must be removed prior to reinstallation.
5. Wipe the sanded mirror support with a clean paper towel saturated with rubbing alcohol. Allow the support to dry.

6. Follow the adhesive kit manufacturer's directions for adhesive application and mirror support preparation before installing the mirror support to the glass.
7. Position the mirror support to its premarked position. Use steady pressure and press the support against the glass for 30 to 60 seconds.
8. After 5 minutes, remove the excess adhesive with

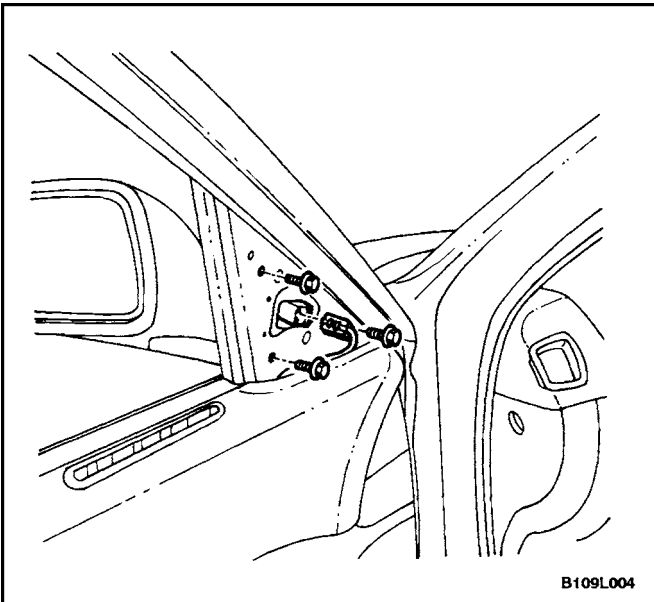
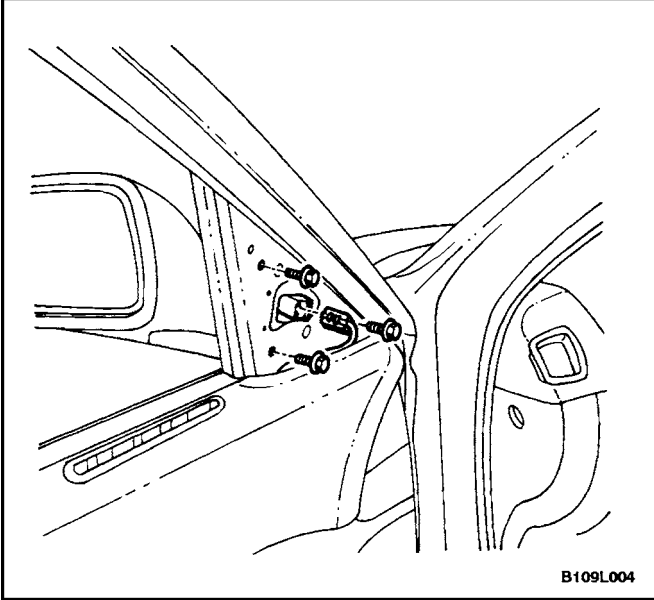

an alcohol-moistened towel or a glass-cleaning solution.

9. Install the inside rearview mirror to the mirror support with the mounting

Tighten

Tighten the rearview mirror mounting screw to 1.5 N•m (13 lb-in).

ELECTRIC CONTROL HEATED OUTSIDE REARVIEW MIRRORS

Removal Procedure

1. Remove the front door tweeter speaker and the escutcheon.
2. Disconnect mirror electrical connector, if equipped.
3. Remove the screws and the outside rearview mirror assembly from the door.

Installation Procedure

Notice : Dissimilar metals in direct contact with each other may corrode rapidly. Make sure to use the correct fasteners to prevent premature corrosion.

1. Install the outside rearview mirror assembly to the door with the screws.

Tighten

Tighten the outside rearview mirror assembly screws to 8 N•m (71 lb-in).

2. Connect the mirror electrical connector.
3. Install the escutcheon and the front door tweeter speaker.

GENERAL DESCRIPTION AND SYSTEM OPERATION

STATIONARY GLASS

Stationary glass consists of all the glass on the vehicle which is immovable within its frame, such as the windshield glass, the back glass, and the inside rearview mirror.

ELECTRIC CONTROL HEATED OUTSIDE REARVIEW MIRRORS

Heated electric control outside rearview mirrors are standard. The outside rearview mirror defroster is activated whenever the rear window defroster is turned on.

INSIDE REARVIEW MIRROR

The rearview mirror pivots at the ball-and-socket mirror pivot and can be manually adjusted up/down and left/right.